



***Ice Crusher***  
***Model IC-IT-0002***  
***Item 17137***  
***Instruction Manual***



*Revised - 05/23/2023*

---

Toll Free: 1-800-465-0234  
Fax: 905-607-0234  
Email: [service@omcan.com](mailto:service@omcan.com)  
[www.omcan.com](http://www.omcan.com)



# ***Table of Contents***

Model IC-IT-0002

---

<b>Section</b>	<b>Page</b>
General Information -----	3 - 4
Safety and Warranty -----	4 - 6
Technical Specifications -----	6
Installation -----	6 - 7
Operation -----	7 - 8
Maintenance -----	9
Parts Breakdown -----	10 - 11
Electrical Schematics -----	12
Notes -----	13 - 14
Warranty Registration -----	15



# General Information

---

Omcan Manufacturing and Distributing Company Inc., Food Machinery of America, Inc. dba Omcan and Omcan Inc. are not responsible for any harm or injury caused due to any person's improper or negligent use of this equipment. The product shall only be operated by someone over the age of 18, of sound mind, and not under the influence of any drugs or alcohol, who has been trained in the correct operation of this machine, and is wearing authorized, proper safety clothing. Any modification to the machine voids any warranty, and may cause harm to individuals using the machine or in the vicinity of the machine while in operation.

## CHECK PACKAGE UPON ARRIVAL

Upon receipt of an Omcan shipment please inspect for external damage. If no damage is evident on the external packaging, open carton to ensure all ordered items are within the box, and there is no concealed damage to the machine. If the package has suffered rough handling, bumps or damage (visible or concealed), please note it on the bill of lading before accepting the delivery and contact Omcan within 24 hours, so we may initiate a claim with the carrier. A detailed report on the extent of the damage caused to the machine must be filled out within three days, from the delivery date shown in the shipping documents. Omcan has no recourse for damaged products that were shipped collect or third party.

**Before operating any equipment, always read and familiarize yourself with all operation and safety instructions.**

Omcan would like to thank you for purchasing this machine. It's of the utmost importance to save these instructions for future reference. Also save the original box and packaging for shipping the equipment if servicing or returning of the machine is required.

---

Omcan Fabrication et distribution Compañie Limité et Food Machinery d'Amérique, dba Omcan et Omcan Inc. ne sont pas responsables de tout dommage ou blessure causé du fait que toute personne ait utilisé cet équipement de façon irrégulière. Le produit ne doit être exploité que par quelqu'un de plus de 18 ans, saine d'esprit, et pas sous l'influence d'une drogue ou d'alcool, qui a été formé pour utiliser cette machine correctement, et est vêtu de vêtements de sécurité approprié. Toute modification de la machine annule toute garantie, et peut causer un préjudice à des personnes utilisant la machine ou des personnes à proximité de la machine pendant son fonctionnement.

## VÉRIFIEZ LE COLIS DÈS RÉCEPTION

Dès réception d'une expédition d'Omcan veuillez inspecter pour dommages externes. Si aucun dommage n'est visible sur l'emballage externe, ouvrez le carton afin de s'assurer que tous les éléments commandés sont dans la boîte, et il n'y a aucun dommage dissimulé à la machine. Si le colis n'a subi aucune mauvaises manipulations, de bosses ou de dommages (visible ou cachée), notez-le sur le bond de livraison avant d'accepter la livraison et contactez Omcan dans les 24 heures qui suivent, pour que nous puissions engager une réclamation auprès du transporteur. Un rapport détaillé sur l'étendue des dommages causés à la machine doit être rempli dans un délai de trois jours, à compter de la date de livraison indiquée dans les documents d'expédition. Omcan n'a aucun droit de recours pour les produits endommagés qui ont été expédiés ou cueilli par un tiers transporteur.

# General Information

---

Avant d'utiliser n'importe quel équipement, toujours lire et vous familiariser avec toutes les opérations et les consignes de sécurité.

Omcan voudrais vous remercier d'avoir choisi cette machine. Il est primordial de conserver ces instructions pour une référence ultérieure. Également conservez la boîte originale et l'emballage pour l'expédition de l'équipement si l'entretien ou le retour de la machine est nécessaire.

---

Omcan Empresa De Fabricacion Y Distribucion Inc. Y Maquinaria De Alimentos De America, Inc. dba Omcan y Omcan Inc. no son responsables de ningun daño o perjuicio causado por cualquier persona inadecuada o el uso descuidado de este equipo. El producto solo podra ser operado por una persona mayor de 18 años, en su sano juicio y no bajo alguna influencia de droga o alcohol, y que este ha sido entrenado en el correcto funcionamiento de esta máquina, y ésta usando ropa apropiada y autorizada. Cualquier modificación a la máquina anula la garantía y puede causar daños a las personas usando la máquina mientras esta en el funcionamiento.

## REVISE EL PAQUETE A SU LLEGADA

Tras la recepcion de un envio Omcan favor inspeccionar daños externos. Si no hay daños evidentes en el empaque exterior, Habra el carton para asegurarse que todos los articulos solicitados estén dentro de la caja y no encuentre daños ocultos en la máquina. Si el paquete ha sufrido un manejo de poco cuidado, golpes o daños (visible o oculto) por favor anote en la factura antes de aceptar la entrega y contacte Omcan dentro de las 24 horas, de modo que podamos iniciar una reclamación con la compañía. Un informe detallado sobre los daños causados a la máquina debe ser llenado en el plazo de tres días, desde la fecha de entrega que se muestra en los documentos de envío. Omcan no tiene ningun recurso por productos dañados que se enviaron a recoger por terceros.

Antes de utilizar cualquier equipo, siempre lea y familiarizarse con todas las instrucciones de funcionamiento y seguridad.

Omcan le gustaría darle las gracias por la compra de esta máquina. Es de la mayor importancia para salvar estas instrucciones para futuras consultas. Además, guarda la caja original y el embalaje para el envío del equipo si servicio técnico o devolución de la máquina que se requiere.

# Safety and Warranty

---

## GENERAL PRECAUTIONS

- The machine must only be used by trained personnel who thoroughly understand the safety regulations contained in this manual.
- If personnel must be alternated provide training ahead of time.
- Before carrying out any cleaning or maintenance operation disconnect the machine plug from the electrical outlet.

# Safety and Warranty

---

- Carefully evaluate residual risks when intervening for maintenance or cleaning (therefore having to remove safety devices).
- Always concentrate while carrying out maintenance or cleaning operations.
- Regularly check the condition of the feeding cable, a worn or split cable is extremely dangerous.
- If there seems to be something wrong with the machine or it does not function correctly, it is advisable to not use it and to not try to repair it directly but to contact the assistance center.
- Use the machine only for chopping ice.
- Do not place hands or other objects into the product inlet and outlet while the machine is running.
- Do not move the machine unless the switch is at "0" (off) and the plug is disconnected.
- The manufacturer cannot be held responsible in the following cases:
  - The machine is mishandled by unauthorized personnel.
  - Machine parts are replaced with unoriginal ones.
  - The instructions in this manual are not followed carefully; unsuitable products are used to treat the machine surfaces.

## SAFETY DEVICES INSTALLED ON THE MACHINE

As far as electrical safety devices are concerned the machine described in this manual complies with the CEE directives 73/23, 89/336 and the CEE regulations EN 60335-1, EN 55014.

The machine is outfitted with the following safety devices:

- Magnetic safety micro on the collection basin.
- Magnetic safety micro on the lever.
- Mechanical safety micro on the back of the machine, which blocks running when the key to adjust blade thickness is inserted.

Even though the machine is outfitted with the regulatory measures for electrical and mechanical protections (both during operation and cleaning and maintenance procedures), there are in any case RESIDUAL RISKS (CEE 89/392 point 1.7.2), which cannot be completely eliminated and are referred to in this manual under ATTENTION.

**RESIDENTIAL USERS: Vendor assumes no liability for parts or labor coverage for component failure or other damages resulting from installation in non-commercial or residential applications. The right is reserved to deny shipment for residential usage; if this occurs, you will be notified as soon as possible.**

## 1 YEAR PARTS AND LABOUR BENCH WARRANTY

Within the warranty period, contact Omcan Inc. at 1-800-465-0234 to schedule a drop off to either an Omcan authorized service depot in the area, or to an Omcan Service warehouse to repair the equipment.

Unauthorized maintenance will void the warranty. Warranty covers electrical and part failures, not improper use.

Please see <https://omcan.com/disclaimer> for complete info.

# Safety and Warranty

---

## WARNING:

The packaging components are classified as normal solid urban waste and can therefore be disposed of without difficulty.

In any case, for suitable recycling, we suggest disposing of the products separately (differentiated waste) according to the current norms.

**DO NOT DISCARD ANY PACKAGING MATERIALS IN THE ENVIRONMENT!**

# Technical Specifications

---

<b>Model</b>	<b>IC-IT-0002</b>
<b>Power</b>	0.3 HP / 0.35 kW
<b>Motor Speed</b>	12,000 RPM
<b>Blade Speed</b>	1,500 RPM
<b>Bowl Capacity</b>	2 L / 2.1 QT
<b>Crushed Ice Maximum Thickness</b>	0.4" / 10mm
<b>Electrical</b>	110-120V / 60Hz / 1
<b>Weight</b>	18.5 lbs. / 8.4 kgs.
<b>Dimensions</b>	18.3" x 8.3" x 11.6" / 465 x 210 x 295mm
<b>Packaging Weight</b>	21 lbs. / 9.5 kgs.
<b>Packaging Dimensions</b>	21" x 11" x 12" / 533 x 279 x 305mm
<b>Item Number</b>	17137

# Installation

---

## CHECKING THE PACKAGE UPON ARRIVAL

If the package does not show any external damage upon arrival, proceed to opening it and check if all the material is inside. On the other hand, if the package shows signs of mishandling, bumps or falls, the carrier must be informed of the damage within three days of the delivery date, indicated on the documents, and write a precise report of the eventual damage done to the machine. Do not turn the package over!! When moving the machine make sure that it is firmly held in the four main points (keeping it parallel to the floor).

# Installation

---

## DISPOSING OF THE PACKAGING

The parts of the package (cardboard, plastic straps) are considered solid urban trash; therefore they can be normally disposed of. If the machine is installed in countries, which have particular laws, dispose of the packages according to the laws in force.

## PLACING THE MACHINE

The plane on which the machine is placed must be wide enough, level, dry, smooth, robust, and stable. Furthermore the machine must be placed in an environment with the maximum humidity of 75%, salt-free and with a temperature between +5°C and +35°C; in any case in environments that do not make the machine malfunction.

# Operation

---

## OPERATIONAL CHECK

**N.B.: Before testing the machine make sure that:**

- The collection basin is in the right position, that is when the micro is aligned with the magnet.
- The key is not inserted in the machine.
- The lever has been lowered enough to react with the magnetic micro.

Then try running the machine using the following procedure:

1. Press the switch into the “I” position.
2. Check if the machine stops running by removing the container.
3. Check if the machine stops running by lifting the lever.
4. At the end put the switch at “0” in the off position.
5. Check if the machine does not start with the key inserted and keeping your hands off the machine.

## MACHINE USE

### CONTROLS

The controls are located on the machine casing as shown in the following diagram.

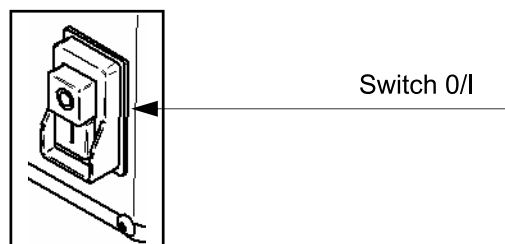

# Operation

---

## POSITION OF SAFETY MICROS ON THE ICE CHOPPER

- Magnetic micro: it blocks the ice chopper from running if the magnet of the basin does not react with the micros inside the machine (they must be aligned).
- Mechanical micro: it blocks the machine when the key is inserted to adjust the blade.
- Magnetic micro on the lever: it blocks the ice chopper from running when the lever has been lifted.

## LOADING THE PRODUCT

**ATTENTION! The ice to be chopped is loaded in the inlet only when the machine motor has stopped.**  
**N.B.: The quantity of ice to be inserted must not overflow from the inlet, otherwise the magnet micro on the lever will not be able to make contact and the machine will not turn on.**

Follow this procedure:

1. Make sure the container is in the right position, so that it makes contact with the micro.
2. Lift the lever so that it opens the inlet cover.
3. Insert the right quantity of ice, the cover must be able to close.
4. Start the machine by using the switch, pressing the "I" button.
5. Exert light pressure on the lever until the ice passes completely in the blade.
6. Assume a correct position to avoid accidents. Your body must be perpendicular with the work plane. Never lean on the machine and avoid positions that bring your body in direct contact with the machine, use the lever.
7. When work is complete stop the machine by pressing the stop "0" button.
8. Avoid making the ice chopper run when empty.
9. Carefully remove the collection container.
10. Once the ice has been emptied from the container, reposition it immediately under the outlet because the ice remaining inside the opening melts with time and dripping on the plane could create risks.
11. Never move the machine if the switch is not off ("0") and the plug disconnected.
12. If the chopped ice does not have the desired consistency use the key (equipped with the machine) to regulate the thickness of the blade to chop the ice more or less thickly.

## ADJUSTING THE BLADE THICKNESS

The following is the procedure for adjusting the thickness of the blade:

1. Put the switch at "0".
2. Disconnect the feed cable to completely isolate the machine from the rest of the system.
3. Insert the key in the hole located on the backside of the ice chopper and turn the key in a clockwise or counterclockwise direction, checking the variation in the blade thickness from the inlet with the lever lifted.
4. Once the desired thickness has been set, remove the key from the hole and connect the plug to start using the ice chopper.



## CLEANING AND DRYING

- The machine does not require particular cleaning.
- The machine must be dried at the end of every work cycle.
- All the parts of the machine must be carefully cleaned by using only a sponge or absorbent cloth.
- The machine must never be cleaned with water cleaners or jets of water, but with water and neutral detergents. Never use utensils, brushes or other that could damage the surface of the machine.

### **ATTENTION! Before carrying out any cleaning operation it is necessary to:**

- Put the switch at "0".
- Disconnect the plug to completely isolate the machine from the rest of the system.

## CLEANING PROCEDURES FOR THE MACHINE

**N.B.: Never wash any part of the ice chopper in a dishwasher machine.**

Before starting to clean the ice chopper extract the container from its place to be able to clean it entirely. The casing of the machine and the inlet/outlet can be cleaned with a neutral detergent and a damp cloth, rinsing it frequently with warm water.

**ATTENTION: once all the parts of the ice chopper have been cleaned, dry them well and reposition the container in its housing and lower the lever.**

## MAINTENANCE

Before doing any maintenance it is necessary to:

Disconnect the plug to completely isolate the machine from the rest of the system.

### **FEEDING CABLE**

Periodically check the state of wear and tear of the cable and call your service provider if it needs to be replaced.

### **BLADE**

Periodically check the state of the blade, contact your service provider if it needs to be replaced.

## DISMANTLING

### **PUTTING OUT OF COMMISSION**

If for some reason you decide to put the machine out of commission make sure that it cannot be used by anyone: remove the blade, disconnect it and cut the electrical connections.

### **DISPOSAL**

Once the machine has been put out of commission it can be eliminated. To correctly dispose of the machine contact any company used for such a service and carefully observe the materials used for the various parts.

# Parts Breakdown

Model IC-IT-0002 17137

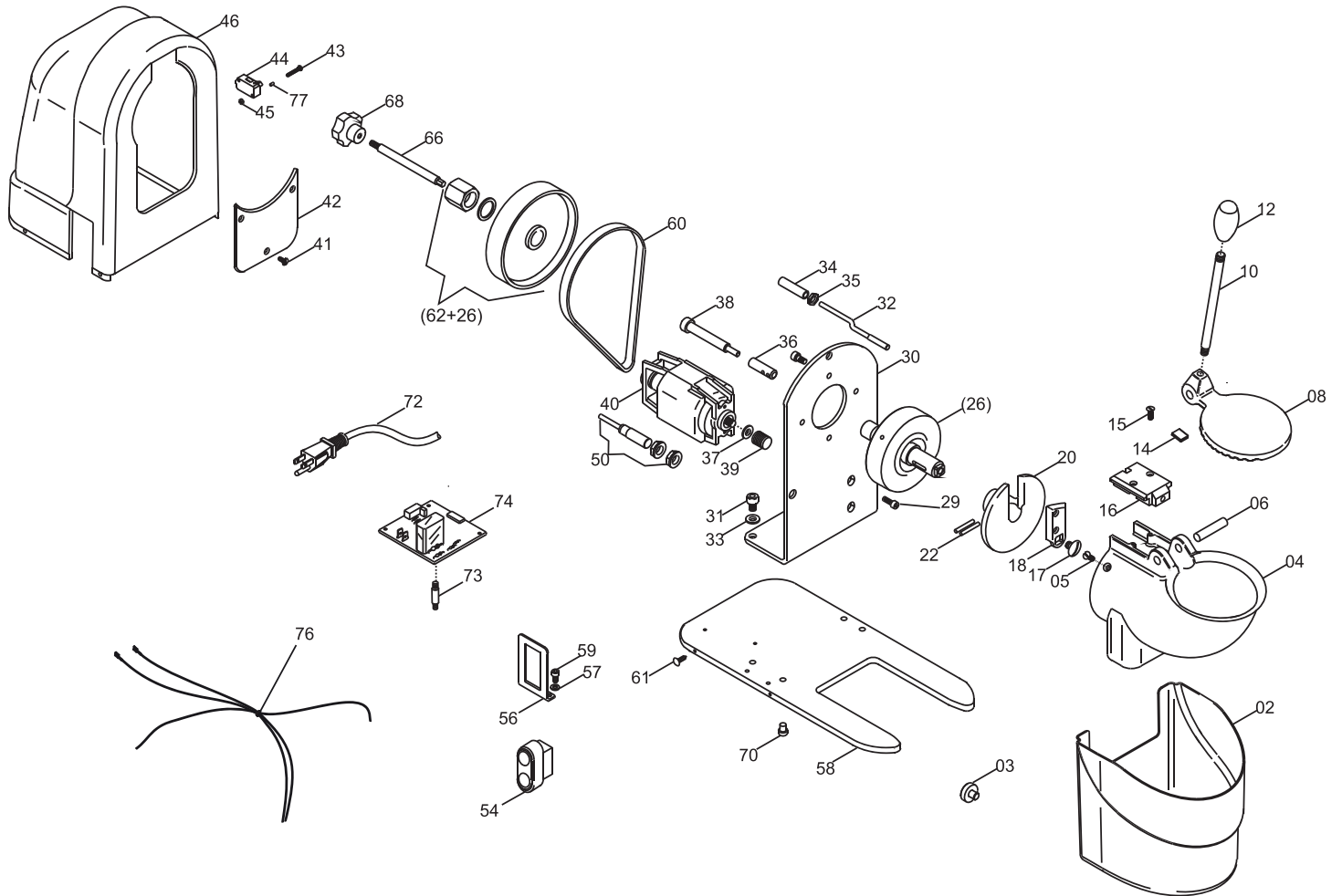

# Parts Breakdown

## Model IC-IT-0002 17137

Item No.	Description	Position	Item No.	Description	Position	Item No.	Description	Position
37378	Grey Container for 17137	02	37361	Opening Microswitch for 17137	32	37371	Container Microswitch for 17137	50
37349	Magnet for Container for 17137	03	37362	Support for Microswitch for 17137	34	76921	On/Off Switch for 17137	54
37350	Coated Opening for 17137	04	37363	Nut for 17137	35	37384	Plate On/Off Switch for 17137	56
37351	Hinge for Opening Cover for 17137	06	37364	Brass Socket for 17137	36	37373	Coated Stand/Base for 17137	58
23650	Mouth Lid for 17137	08	37365	Motor Pulley Washer for 17137	37	21848	Belt for 17137	60
23651	Knob Rod for 17137	10	37366	Screw for 17137	38	37374	Pulley Disc Flange Assy for 17137	62+26
23652	Pusher Knob for 17137	12	37367	Motor Pulley for 17137	39	39314	Blade Adj. Rod for 17137	66
37352	Magnet for Opening for 17137	14	67015	Motor 115V/60Hz for 17137	40	23657	Blade Adjusting Knob for 17137	68
37353	Microswitch Support for 17137	16	37369	Cover for 17137	42	37376	Foot for 17137	70
37354	Left Fixing Screw for Blade for 17137	17	67016	Zinc Screw M3x30 for 17137	43	67018	US Power Cord for 17137	72
23659	Stainless Steel Blade for 17137	18	23653	Microswitch for 17137	44	37377	Distance Piece for 17137	73
37355	Blade Disc for 17137	20	67017	Nut M3 for 17137	45	23658	Circuit Board 110V for 17137	74
76919	Stainless Steel Plug D4x3.5 for 17137	22	37380	Grey Frame for 17137	46	67019	Internal Wires for 17137	76
37360	Motor Plate for 17137	30	37370	Strain Relief PVC Dia. 7 for 17137	48	67020	Spacer for 17137	77

# Electrical Schematics

Model IC-IT-0002 17137

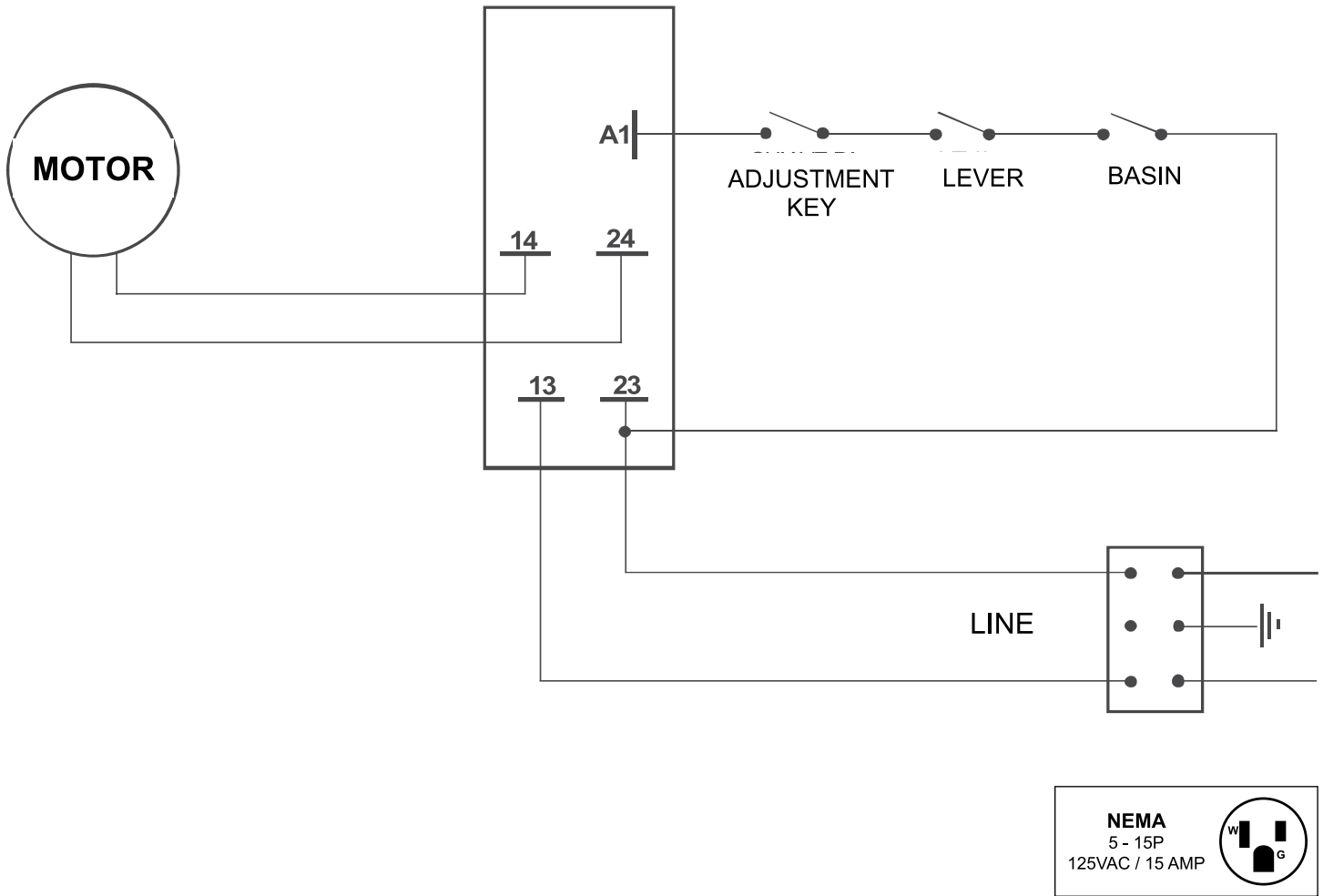

## *Notes*

---

---

---

---

---

---

---

---

---

---

---

---

---

---

---

---

---

---

---

---

---

---

---

---

---

---

---

---

---





# Warranty Registration

Thank you for purchasing an Omcan product. To register your warranty for this product, complete the information below, tear off the card at the perforation and then send to the address specified below. You can also register online by visiting:

Merci d'avoir acheté un produit Omcan. Pour enregistrer votre garantie pour ce produit, complétez les informations ci-dessous, détachez la carte au niveau de la perforation, puis l'envoyer à l'adresse spécifiée ci-dessous. Vous pouvez également vous inscrire en ligne en visitant:

Gracias por comprar un producto Omcan usted. Para registrar su garantía para este producto, complete la información a continuación, cortar la tarjeta en la perforación y luego enviarlo a la dirección indicada a continuación. También puede registrarse en línea en:

<https://omcan.com/warranty-registration/>

For mailing in Canada

Pour postale au Canada

Por correo en Canadá

For mailing in the US

Pour diffusion aux États-Unis

Por correo en los EE.UU.

**OMCAN**

PRODUCT WARRANTY REGISTRATION

3115 Pepper Mill Court,

Mississauga, Ontario

Canada, L5L 4X5

**OMCAN**

PRODUCT WARRANTY REGISTRATION

4450 Witmer Industrial Estates, Unit 4,

Niagara Falls, New York

USA, 14305

*or email to: [service@omcan.com](mailto:service@omcan.com)*



Purchaser's Information

Name: \_\_\_\_\_

Address: \_\_\_\_\_

City: \_\_\_\_\_ Province or State: \_\_\_\_\_ Postal or Zip: \_\_\_\_\_

Country: \_\_\_\_\_

Dealer from which Purchased: \_\_\_\_\_

Dealer City: \_\_\_\_\_ Dealer Province or State: \_\_\_\_\_

Invoice: \_\_\_\_\_

Model Name: \_\_\_\_\_ Model Number: \_\_\_\_\_

Machine Description: \_\_\_\_\_

Date of Purchase (MM/DD/YYYY): \_\_\_\_\_

Would you like to extend the warranty?  Yes  No

Company Name: \_\_\_\_\_

Telephone: \_\_\_\_\_

Email Address: \_\_\_\_\_

Type of Company:

Restaurant  Bakery  Deli

Butcher  Supermarket  Caterer

Institution (specify): \_\_\_\_\_

Other (specify): \_\_\_\_\_

Serial Number: \_\_\_\_\_

Date of Installation (MM/DD/YYYY): \_\_\_\_\_

**Thank you for choosing Omcan | Merci d'avoir choisi Omcan | Gracias por elegir Omcan**



Since 1951 Omcan has grown to become a leading distributor of equipment and supplies to the North American food service industry. Our success over these many years can be attributed to our commitment to strengthen and develop new and existing relationships with our valued customers and manufacturers. Today with partners in North America, Europe, Asia and South America, we continually work to improve and grow the company. We strive to offer customers exceptional value through our qualified local sales and service representatives who provide convenient access to over 6,500 globally sourced products.

---

Depuis 1951 Omcan a grandi pour devenir un des “leaders” de la distribution des équipements et matériel pour l’industrie des services alimentaires en Amérique du Nord. Notre succès au cours de ces nombreuses années peut être attribué à notre engagement à renforcer et à développer de nouvelles et existantes relations avec nos clients et les fabricants de valeur. Aujourd’hui avec des partenaires en Amérique du Nord, Europe, Asie et Amérique du Sud, nous travaillons continuellement à améliorer et développer l’entreprise. Nous nous efforçons d’offrir à nos clients une valeur exceptionnelle grâce à nos ventes locales qualifiées et des représentants de service qui offrent un accès facile à plus de 6500 produits provenant du monde entier.

---

Desde 1951 Omcan ha crecido hasta convertirse en un líder en la distribución de equipos y suministros de alimentos en América del Norte industria de servicios. Nuestro éxito en estos años se puede atribuir a nuestro compromiso de fortalecer y desarrollar nuevas relaciones existentes con nuestros valiosos clientes y fabricantes. Hoy con socios de América del Norte, Europa, Asia y América del Sur, que trabajan continuamente para mejorar y crecer la empresa. Nos esforzamos por ofrecer a nuestros clientes valor excepcional a través de nuestro local de ventas y representantes de los servicios que proporcionan un fácil acceso a más de 6,500 productos con origen a nivel mundial.

